

P800L Series

Part Numbering System P800L - 72 - 2.0
 Fuse Type Voltage Amp

Short Form Catalog

Fuse Part Number/Rating			Cold Resistance (Ohm)		Overload Interrupt			Maximum I ² T (Ampere ² Second)		
P800L Part No.	Maximum voltage (VDC)	Current Rating (AMP)	Minimum	Maximum	250%	400%	600%	250%	400%	600%
P800L-72-2.0	72	2.0	0.0450	0.0750	1.0 - 150.0	.004 - .060	.0008 - .008	3750.000	3.840	1.152
P800L-72-3.0	72	3.0	0.0285	0.0475	.500 - 30.0	.006 - .090	.0008 - .008	1687.500	12.960	2.592
P800L-72-4.0	72	4.0	0.0217	0.0363	.500 - 30.0	.008 - .120	.0007 - .014	3000.000	30.720	8.064
P800L-72-5.0	72	5.0	0.0187	0.0313	.500 - 30.0	.006 - .090	.0008 - .016	4687.500	36.000	14.400
P800L-72-7.5	72	7.5	0.0120	0.0200	.500 - 30.0	.005 - .080	.0008 - .012	10546.875	72.000	24.300
P800L-72-10.0	72	10.0	0.0075	0.0125	.500 - 30.0	.010 - .150	.0008 - .012	18750.000	240.000	43.200
P800L-72-15.0	72	15.0	0.0045	0.0075	.500 - 20.0	.010 - .150	.0008 - .012	28125.000	540.000	97.200

NOTES:

1. Cold resistance is measured at from 0.1 to 10 milliamperes of current.
2. Overload interrupt times listed are for case temperatures of +25°C to +125°C. Case temperature outside of this range may affect overload interrupt times.

Please see P800L Spec Sheets for figures detailing dimensions, construction and marking



AEM, INC.

11525 Sorrento Valley Rd.
San Diego, California 92121
(858) 481- 0210

SPECIFICATION SHEET

P800L CURRENT LIMITING FUSE

SLOW-BLOW MODEL

REVISION:	A	B	C							
DATE:	10/95	2/96	2/00							
DRAWN:	Jeff Montgomery									
CHECKED:	Yan Ma									
APPROVED:	Jeff Montgomery									
ECN:	2117			SHEET 1 OF 21						

1. SCOPE

1.1 Scope. This specification establishes the requirements for solid body current limiting fuses. Fuses described in this document are designed and manufactured for high reliability applications based on guaranteed blow limits. These fuses are intended for use in direct (DC) and alternating current (AC) circuits and are capable of operation over a temperature range of -55°C to +125°C ambient including high vacuum environments.

2. LOT ACCEPTANCE TESTING

2.1 Lot Acceptance Testing. This specification provides for two acceptance levels for the procurement of fuses. The degree of testing and associated documentation can be specified as appropriate to the end use of the fuses. Regardless of the acceptance level specified, the inherent quality and reliability of the fuses will remain constant. The acceptance levels with the applicable inspection required are indicated in Table I.

TABLE I. LOT ACCEPTANCE LEVEL.

LOT ACCEPTANCE LEVEL	INSPECTION TO BE PERFORMED		
	GROUP A	GROUP B	GROUP C
LAT 2	X	X	
LAT 1	X	X	X

3. APPLICABLE DOCUMENTS

3.1 Issues of Documents. The following specifications, standards and handbooks form a part of this specification to the extent specified herein. In the event of a conflict between the documents referenced herein and this specification, this specification governs.

SPECIFICATIONS

- MIL-G-45204: Gold Plating Electrodeposited.
- MIL-PRF-23419: General Specification for Instrument Type Fuses.
- MIL-F-14256: Flux, Soldering, Liquid (Rosin Base).

STANDARDS

- MIL-STD-202: Test Methods for Electronic and Electrical Component Parts.
- MIL-STD-790: Reliability Assurance Program for Electronic Parts Specifications.
- MIL-STD-1285: Marking of Electrical and Electronic Parts.
- MIL-STD-45662: Calibration System Requirements.

OTHERS

AEM, Inc.	11525 SORRENTO VALLEY RD SAN DIEGO, CA 92121-1306.		TITLE P800L SPECIFICATION
NUMBER P800L	REVISION C	ECN 2117	SHEET 2 of 21

P600L-PA:	Internal Visual Examination (Precap) for Current Limiting Fuses.
P800L-R:	Radiographic Inspection for Current Limiting Fuses.
ASTM E595:	Materials from Outgassing in a Vacuum Environment, Total Mass Loss and Collected Volatile Condensable, Standard Test Method for.

4. REQUIREMENTS

4.1 Qualification. Fuses manufactured in accordance with this document shall be capable of passing the qualification requirements specified in Table V and section 4 of this document.

4.2 Materials, Design and Construction. The materials, design and construction of the fuses shall be as specified herein (see Figure 4 for flow chart of operations).

4.2.1 Terminals. The lead material shall be CDA-102 copper, plated with gold per MIL-G-45204, Type II, Grade C, Class 1 with nickel underplate of 50 micro-inches.

4.2.2 Housing. The housing material shall be polyphenylene sulfide (PPS). The PPS material shall be insert molded to form the body of the fuse.

4.3 Voltage Rating. The voltage rating for fuses specified herein is 72 volts DC.

4.4 Current Rating. The current rating is the maximum amperes that the fuse will carry at a case temperature of +25°C without degradation. The applicable current ratings are specified in Table VI.

4.5 Temperature Rating. The temperature rating for fuses specified herein is -55°C to +150°C nonoperating. The maximum operating temperature shall not exceed a case temperature of +125°C. The temperature derating curve is given in Figure 3.

4.6 Resistance Rating. The cold resistance of the fuses shall be as specified in Table VI when measured in accordance with 5.8.2.

4.7 Marking. Fuses shall be marked in accordance with Method I of MIL-STD-1285. Adhesive type mylar labels used in serialization shall be suitably protected with a clear epoxy. The following information shall be marked on each fuse:

- a) AEM Part Number (see Table VI)
- b) Non-recurring serial number
- c) Voltage rating (VDC)
- d) Current rating in amperes
- e) Manufacture lot code (C-Lot)
- f) AEM logo

Note: For marking example, please refer to Figure 1.

4.8 Performance.

4.8.1 Thermal Shock. When fuses are tested in accordance with 5.8.3 herein, they shall show no electrical or mechanical damage and there shall be no loosening of the terminals. Their voltage drops shall not change by more than 10 percent from the pre-thermally shocked values.

4.8.2 Burn-in. When fuses are tested in accordance with 5.8.4, they shall not open circuit nor shall their voltage drops change by more than 10 percent from the pre-thermally shocked values. There shall be no mechanical damage as a result of this testing.

4.8.3 Dielectric Strength. When fuses are tested in accordance with 5.8.5, the leakage current shall not exceed 1 milliampere.

AEM, Inc.		11525 SORRENTO VALLEY RD SAN DIEGO, CA 92121-1306.		TITLE P800L SPECIFICATION
NUMBER	P800L	REVISION	C	ECN 2117
				SHEET 3 of 21

4.8.4 X-Ray Inspection. When fuses are tested in accordance with 5.8.6, there shall be no rejections.

4.8.5 Current-Carrying Capacity (Group C / Qualification Only). When fuses are tested in accordance with 5.8.7, they shall show no evidence of mechanical damage and shall carry the current as specified without electrical failure. The temperature of the case or terminals shall at no point rise more than +85°C above the ambient air temperature. The maximum temperature rise for 6.0, 7.5, 10, 15 and 20 ampere fuses shall be +120°C.

4.8.6 Terminal Strength. When fuses are tested in accordance with 5.8.8, the lead terminals shall not break or loosen. The cold resistance values shall not change by more than 10 percent.

4.8.7 Thermal Vacuum (Qualification Only). When fuses are tested in accordance with 5.8.17, they shall not open circuit during the application of derated DC current nor shall there be evidence of arcing or mechanical damage after the test. Fuses that are subjected to the 400 percent overload current test shall "blow" within the time period specified (see Table VI). The cold resistance values of those fuses not subjected to the overload current shall not change by more than 10 percent when measured after thermal vacuum exposure.

4.8.8 Overload Current.

4.8.8.1 Overload Current Characterization. Each fuse lot shall be sampled to assure that the blow times fall within the limits of Table VI. Each lot shall be truncated to form an inspection lot based upon the Final Voltage Drop after burn-in. The manufacturer shall blow samples (a minimum of 20 samples total) selected from the extremes of the truncated population to insure that their blow times are within the specification. The results of this procedure shall be provided in the "Group A Data" with the lot data package.

4.8.8.2 Overload Current. Fuses selected from a truncated distribution shall be tested in accordance with 5.8.15. The clearing times and the maximum I^2t shall be as specified in Table VI. After clearing, the circuit shall remain open without closing again during a one-minute period. The let through energy during the one-minute period shall be included in the calculation of I^2t . The blown fuses shall meet the resistance after firing test of 4.8.9.

4.8.9 Resistance after Firing. When blown fuses are tested in accordance with 5.8.16, the minimum resistance shall be 10 megohms. The following exceptions shall apply for fuses with current ratings greater than 5 amperes:

- a) 250% Overload - A resistance value of 100K ohms minimum following the 250% overload test.
- b) Other Overloads - A resistance value of 1 megohm minimum following overload testing.

4.8.10 Moisture Resistance (Group C / Qualification Only). When fuses are tested in accordance with 5.8.9, there shall be no evidence of cracking or peeling of the fuse body, loosening of the terminals or excessive corrosion of the leads. The resistance of the fuses shall not change by more than 15 percent as a result of the moisture exposure.

AEM, Inc.	11525 SORRENTO VALLEY RD SAN DIEGO, CA 92121-1306.	TITLE P800L SPECIFICATION
NUMBER P800L	REVISION C	ECN 2117
		SHEET 4 of 21

4.8.11 Shock (Group C / Qualification Only). When fuses are tested in accordance with 5.8.10, there shall be no evidence of mechanical damage and the fuse resistance shall not change by more than 10 percent.

4.8.12 Vibration (Group C / Qualification Only). When fuses are tested in accordance with 5.8.11, there shall be no evidence of mechanical damage and the fuse resistance shall not change by more than 10 percent.

4.8.13 Low Temperature Operation (Group C / Qualification Only). When fuses are tested in accordance with 5.8.13, they shall not open circuit and the fuse resistance shall not change by more than 10 percent.

4.8.14 Life (2000 Hours, Group C / Qualification Only). When fuses are tested in accordance with 5.8.14, they shall not open circuit and the fuse resistance shall not change by more than 10 percent.

4.8.15 Resistance to Soldering Heat (Group C / Qualification Only). When fuses are tested in accordance with 5.8.12, there shall be no mechanical damage and the fuse resistance shall not change by more than 10 percent.

4.8.16 Solderability. Fuses shall meet the solderability requirements specified in MIL-STD-202, Method 208. Prior to testing, gold plated leads shall have the gold removed by single or double dipping into a flowing or nonflowing hot solder of sufficient volume to assure complete gold removal.

4.8.17 Salt Spray (Group C / Qualification Only). When fuses are tested in accordance with 5.8.18, there shall be no evidence of excessive corrosion. Excessive corrosion is defined as that which interferes with the electrical or mechanical performance. There shall be no warping or cracking of the fuse body and the fuse resistance shall not change by more than 10 percent.

4.8.18 Outgassing (Qualification Only). When fuses are tested in accordance with 5.8.19, the materials shall meet the following requirements:

- a) Total mass loss (TML) - Shall not exceed 1.0 percent.
- b) Collected volatile condensable material (CVCM) - Shall not exceed 0.1 percent.

4.8.19 Short Circuit Interrupt (Group C / Qualification Only). When fuses are tested in accordance with 5.8.20, the resistance after short circuit testing shall be at least 1.0 megohm.

4.9 Workmanship. Fuses shall meet the visual and mechanical criteria outlined in AEM Process Instructions P70617 and P70765 when inspected per 5.8.1.

4.9.1 Precap Inspection. Prior to molding all fuses shall be visually inspected with a minimum of 10 power magnification. Inspection criteria are outlined in the AEM Precap Document P600L-PA.

5. QUALITY ASSURANCE PROVISIONS

5.1 Classification of Inspection. The inspection of fuses procured to the requirements of this specification shall be classified as follows:

- a) Qualification Inspection (paragraph 5.6) when specified on the purchase order.
- b) Acceptance Inspection (paragraph 5.7).

5.2 Reliability Assurance Program. AEM shall ensure that a reliability assurance program is established and maintained in accordance with MIL-STD-790.

5.3 Test Equipment and Inspection Facilities. AEM shall establish and maintain a calibration system in accordance with MIL-STD-45662.

5.4 Acceptance Inspection Reports. AEM shall supply with each shipment of fuses the following minimum data:

AEM, Inc.	11525 SORRENTO VALLEY RD SAN DIEGO, CA 92121-1306.	TITLE P800L SPECIFICATION
NUMBER P800L	REVISION C	ECN 2117
		SHEET 5 of 21

- a) All variables data accumulated during Group A and Group B inspections. Group C data, if required on the purchase order, shall be shipped at the completion of Group C inspection.
- b) Customer specified test reports.
- c) Certification of Conformance signed by Quality Assurance Manager.

5.5 Inspection Conditions and Methods. Unless otherwise specified in this document, inspections shall be conducted at room ambient environments of +25°C +/- 5°C and the maximum relative humidity shall be 75 percent.

5.6 Qualification Inspection.

5.6.1 Qualification Samples. Samples submitted to qualification inspection shall be representative of the normal high reliability production. A sample of 32 fuses representing the lowest, middle, and highest voltage drops within the truncated distribution shall be submitted for qualification inspection. At the completion of Subgroup I inspection, the 32 samples shall be divided into the subgroups and quantities shown in Table V. Each subgroup shall have approximately equal representation of the fuse voltage drops.

5.7 Acceptance Inspection.

5.7.1 Inspection of Fuses for Delivery. Inspection of fuses for delivery against a purchase order shall consist of the tests listed in Table I.

5.7.2 Inspection Lot. An inspection lot shall consist of one amperage rating of one lot date code.

5.7.3 Group A Inspection. Group A inspection shall consist of the tests listed in Table II and shall be conducted in the order indicated.

5.7.4 Group B Inspection. Group B inspection shall consist of the tests listed in Table III and shall be conducted in the order indicated. All fuses submitted to Group B inspection shall have successfully met all electrical requirements of the Group A inspection (Visual rejects and X-Ray rejects may be utilized for Group B inspection).

5.7.5 Group C Inspection. Group C inspection, when required by the purchase order, shall consist of the tests listed in Table IV. The fuses submitted for Group C inspection shall have met Group A and Group B inspection requirements as part of the inspection lot from which they were taken. Group C inspection must be completed within 150 days after the completion of Group B inspection.

AEM, Inc.		11525 SORRENTO VALLEY RD SAN DIEGO, CA 92121-1306.		TITLE P800L SPECIFICATION
NUMBER	P800L	REVISION	C	ECN 2117
				SHEET 6 of 21

TABLE II. GROUP A INSPECTION.

EXAMINATION OR TEST	REQUIREMENT PARAGRAPH	METHOD PARAGRAPH	NUMBER OF UNITS SPECIFIED	NUMBER OF DEFECTIVES ALLOWED
PRECAP INSPECTION	4.9.1		100%	N/A
VISUAL AND MECHANICAL EXAMINATION	4.9	5.8.1	100%	N/A
THERMAL SHOCK	4.8.1	5.8.3	100%	/1
BURN-IN	4.8.2	5.8.4	100%	/1
RESISTANCE	4.6	5.8.2	100%	N/A
OVERLOAD CURRENT CHARACTERIZATION	4.8.8.1	5.8.15	AS REQUIRED (20 PCS. MIN.)	N/A
X-RAY INSPECTION	4.8.4	5.8.6	100%	N/A
VISUAL AND MECHANICAL EXAMINATION	4.9	5.8.1	100%	N/A
DIELECTRIC STRENGTH	4.8.3	5.8.5	MIL-PRF-23419 (APPENDIX)	0

1/ THE MAXIMUM PDA FOR THERMAL SHOCK AND BURN-IN TESTS COMBINED IS 5%.

AEM, Inc.	11525 SORRENTO VALLEY RD SAN DIEGO, CA 92121-1306.		TITLE P800L SPECIFICATION
NUMBER P800L	REVISION C	ECN 2117	SHEET 7 of 21

TABLE III. GROUP B INSPECTION.

EXAMINATION OR TEST	REQUIREMENT PARAGRAPH	METHOD PARAGRAPH	NUMBER OF UNITS SPECIFIED 1/	NUMBER OF DEFECTIVES ALLOWED
TERMINAL STRENGTH	4.8.6	5.8.8	20	0
OVERLOAD CURRENT (+25C)	4.8.8.2	5.8.15	20	0
RESISTANCE AFTER FIRING	4.8.9	5.8.16	20	0
SOLDERABILITY	4.8.16		20	0

1/ OVERLOAD CURRENT SAMPLES SHALL BE AS FOLLOWS:

250% OVERLOAD CURRENT – 12 SAMPLES.

400% OVERLOAD CURRENT – 4 SAMPLES.

600% OVERLOAD CURRENT – 4 SAMPLES.

AEM, Inc.	11525 SORRENTO VALLEY RD SAN DIEGO, CA 92121-1306.	TITLE P800L SPECIFICATION	
NUMBER P800L	REVISION C	ECN 2117	SHEET 8 of 21

TABLE IV. GROUP C INSPECTION.

EXAMINATION OR TEST	REQUIREMENT PARAGRAPH	METHOD PARAGRAPH	NUMBER OF UNITS SPECIFIED	NUMBER OF DEFECTIVES ALLOWED
<u>SUBGROUP I (16 UNITS)</u>				
LOW TEMP. OPERATION	4.8.13	5.8.13	12	0
LIFE (2000 HOURS)	4.8.14	5.8.14	12	0
OVERLOAD CURRENT	4.8.8.2	5.8.15	12	0
RESISTANCE AFTER FIRING	4.8.9	5.8.16	12	0
SHORT CIRCUIT INTERRUPT	4.8.19	5.8.20	4	0
RESISTANCE AFTER FIRING	4.8.9	5.8.16	4	0
<u>SUBGROUP II (6 UNITS)</u>				
TERMINAL STRENGTH	4.8.6	5.8.8	6	0
OVERLOAD CURRENT	4.8.8.2	5.8.15	6	0
(MAX. CLEARING AT 600%)	4.8.8.2	5.8.15		
RESISTANCE AFTER FIRING	4.8.9	5.8.16	6	0
<u>SUBGROUP III (4 UNITS)</u>				
VIBRATION	4.8.12	5.8.11	4	0
SHOCK	4.8.11	5.8.10	4	0
RES. TO SOLDERING HEAT	4.8.15	5.8.12	4	0
<u>SUBGROUP IV (4 UNITS)</u>				
SALT SPRAY	4.8.17	5.8.18	4	0
OVERLOAD CURRENT (+25C)	4.8.8.2	5.8.15	4	0
(MAX. CLEARING AT 600%)	4.8.8.2	5.8.15		
RESISTANCE AFTER FIRING	4.8.9	5.8.16	4	0
<u>SUBGROUP V (4 UNITS)</u>				
MOISTURE RESISTANCE	4.8.10	5.8.9	4	0
THERMAL SHOCK	4.8.1	5.8.3	4	0
CURRENT-CARRYING CAP. AT ROOM TEMP. (+25C)	4.8.5	5.8.7	4	0

AEM, Inc.	11525 SORRENTO VALLEY RD SAN DIEGO, CA 92121-1306.		TITLE P800L SPECIFICATION
NUMBER P800L	REVISION C	ECN 2117	SHEET 9 of 21

TABLE V. QUALIFICATION INSPECTION.

EXAMINATION OR TEST	REQUIREMENT PARAGRAPH	METHOD PARAGRAPH	NUMBER OF UNITS SPECIFIED	NUMBER OF DEFECTIVE ALLOWED
<u>SUBGROUP I (32 UNITS)</u>				
VISUAL AND MECHANICAL EXAMINATION	4.9	5.8.1	ALL	0
RESISTANCE	4.6	5.8.2	ALL	0
CURRENT-CARRYING CAP.	4.8.5	5.8.7	ALL	0
<u>SUBGROUP II (6 UNITS)</u>				
TERMINAL STRENGTH	4.8.6	5.8.8	6	0
OVERLOAD CURRENT (HIGH/LOW TEMPS. AND MAX. CLEARING AT 600%)	4.8.8.2	5.8.15	6	0
RESISTANCE AFTER FIRING	4.8.9	5.8.16	6	0
SOLDERABILITY	4.8.16		6	0
<u>SUBGROUP III (14 UNITS)</u>				
LOW TEMP. OPERATION	4.8.13	5.8.13	6	0
LIFE (2000 HOURS)	4.8.14	5.8.14	6	0
OVERLOAD CURRENT (+25C)	4.8.8.2	5.8.15	6	0
RESISTANCE AFTER FIRING	4.8.9	5.8.16	6	0
THERMAL VACUUM	4.8.7	5.8.17	4	0
OVERLOAD CURRENT (400%)	4.8.8.2	5.8.15	2	0
RESISTANCE AFTER FIRING	4.8.9	5.8.16	2	0
SHORT CIRCUIT INTERRUPT	4.8.19	5.8.20	4	0
RESISTANCE AFTER FIRING	4.8.9	5.8.16	4	0
<u>SUBGROUP IV (4 UNITS)</u>				
VIBRATION	4.8.12	5.8.11	4	0
SHOCK	4.8.11	5.8.10	4	0
<u>SUBGROUP V (4 UNITS)</u>				
SALT SPRAY	4.8.17	5.8.18	4	0
OVERLOAD CURRENT (+25C)	4.8.8.2	5.8.15	4	0
(MAX. CLEARING AT 600%)	4.8.8.2	5.8.15		
RESISTANCE AFTER FIRING	4.8.9	5.8.16	4	0
<u>SUBGROUP VI (4 UNITS)</u>				
OUTGASSING	4.8.18	5.8.19	4	0
MOISTURE RESISTANCE	4.8.10	5.8.9	4	0
THERMAL SHOCK	4.8.1	5.8.3	4	0
RES. TO SOLDERING HEAT	4.8.15	5.8.12	4	0
CURRENT CARRYING CAP. AT ROOM TEMP. (+25C)	4.8.5	5.8.7	4	0
OVERLOAD CURRENT (+25C)	4.8.8.2	5.8.15	4	0
RESISTANCE AFTER FIRING	4.8.9	5.8.16	4	0

AEM, Inc.	11525 SORRENTO VALLEY RD SAN DIEGO, CA 92121-1306.	TITLE P800L SPECIFICATION
NUMBER P800L	REVISION C	ECN 2117
SHEET 10 of 21		

TABLE VI. ELECTRICAL AND MECHANICAL REQUIREMENTS.

FUSE PART NUMBER / RATINGS			COLD RESISTANCE (OHMS) 1/		FIGURE	OVERLOAD INTERRUPT TIME (SECONDS) 2/			MAXIMUM I ² T (AMPERE ² SECONDS)		
P800L PART NO.	MAXIMUM VOLTAGE (VDC)	CURRENT RATING (AMPS)	MINIMUM	MAXIMUM		250 % NOMINAL RATING	400 % NOMINAL RATING	600% NOMINAL RATING	250 % NOMINAL RATING	400 % NOMINAL RATING	600% NOMINAL RATING
P800L-72-2.0	72	2.0 A	0.0450	0.0750	1	1.0-150.0	.004-.060	.0008-.008	3750.000	3.840	1.152
P800L-72-3.0	72	3.0 A	0.0285	0.0475	1	.500-30.0	.006-.090	.0008-.008	1687.500	12.960	2.592
P800L-72-4.0	72	4.0 A	0.0217	0.0363	1	↑ ↓	.008-.120	.0007-.014	3000.000	30.720	8.064
P800L-72-5.0	72	5.0 A	0.0187	0.0313	1		.006-.090	.0008-.016	4687.500	36.000	14.400
P800L-72-7.5	72	7.5 A	0.0120	0.0200	1		.005-.080	.0008-.012	10546.875	72.000	24.300
P800L-72-10.0	72	10 A	0.0075	0.0125	1	.500-30.0	.010-.150	.0008-.012	18750.000	240.000	43.200
P800L-72-15.0	72	15 A	0.0045	0.0075	1	.500-20.0	.010-.150	.0008-.012	28125.000	540.000	97.200

1/ Cold resistance is measured at from 0.1 to 10 milliamperes of current.

2/ Overload interrupt times listed are for case temperatures of +25°C - +125°C. Case temperatures outside of this range may affect overload interrupt times.

AEM, Inc.		11525 SORRENTO VALLEY RD SAN DIEGO, CA 92121-1306.		TITLE P800L SPECIFICATION	
NUMBER P800L	REVISION C	ECN 2117	SHEET 11 of 21		

5.8 Methods of Examination and Test.

5.8.1 Visual and Mechanical Inspection. Fuses shall be visually and mechanically examined per AEM Process Instruction P70617 following the molding operation. Fuses shall be visually and mechanically examined per AEM Process Instruction P70765 following the final assembly marking and sealing operations.

5.8.2 Resistance. The resistance of the fuse shall be measured using a constant current DC source having an open circuit voltage not greater than the voltage rating of the fuse. The measurement current shall be from 0.1 to 10 milliamperes and provide a measurement accuracy of +/- 1%. A Keithley Model 580 or equivalent is recommended for these measurements. Measurements shall be taken at room ambient conditions as close to the fuse element as is possible.

5.8.3 Thermal Shock. Fuses shall be tested in accordance with Method 107, Test Condition B, of MIL-STD-202. A total of five cycles shall be run without interruption. The voltage drops of the fuses shall be measured before the five cycles in accordance with 5.8.4.1. The burn-in test of 5.8.4 shall follow this test.

5.8.4 Burn-in. Fuses shall be mounted by their terminals in suitable mount sockets. Spacing between adjacent fuses shall not be less than 0.1 inches or greater than 1 inch. Fuses shall be electrically connected to a constant DC source supplying rated current through each fuse. Current shall be applied for 168 +4 / -0 hours while at room ambient conditions (+25°C to +28°C). Forced air shall not flow over the fuses during this burn-in period. The voltage drop of each fuse shall be measured in accordance with 5.8.4.1 after the burn-in period with the voltage drop change determined from the measurement taken before the thermal shock test of 5.8.3.

5.8.4.1 Voltage Drop at Rated Current. The voltage drop of the fuse shall be measured at room ambient conditions while rated DC current is flowing through the fuse. The measurement shall be made to +/- 1 percent accuracy with the voltage probes placed as close to the fuse element as is practical.

5.8.5 Dielectric Strength. Fuses shall be tested in accordance with Method 301 of MIL-STD-202. Fuses shall be mounted in a test fixture capable of exposing all major surfaces of the fuse body and leads to the test voltage. The test voltage shall be applied to the terminals electrically tied together and to the test fixture. The following details shall apply:

- a) Test voltage - 500 VRMS.
- b) Duration - 5 seconds for acceptance tests.
- 60 seconds for qualification tests.
- c) Leakage current - 1 milliampere maximum.
- d) Measurements - DC resistance of the fuse after the dielectric strength exposure in accordance with 5.8.2.

5.8.6 X-Ray Inspection. Fuses shall be subjected to radiographic inspection in accordance with Method 209 of MIL-STD-202. The following details shall apply:

- a) The radiograph shall be of sufficient quality to render a clear, sharp image of the penetrameter.
- b) The source-object distance shall ensure a sharply defined image.
- c) Two views of each fuse (0° and 90°) shall be provided.
- d) A radiograph penetrameter shall be included on each radiographic film.
- e) Radiographs shall be examined at 10X magnification for the defects specified in AEM P800L-R Specification.

AEM, Inc.	11525 SORRENTO VALLEY RD SAN DIEGO, CA 92121-1306.	TITLE P800L SPECIFICATION
NUMBER P800L	REVISION C	ECN 2117
		SHEET 12 of 21

5.8.7 Current-Carrying Capacity (Group C / Qualification Only). Fuse samples shall be apportioned and submitted to the following DC test currents at -55°C to -60°C, at +20°C to +35°C (room ambient temperature), and at +125°C to +130°C:

<u>Test Temperature</u>	<u>DC Test Current</u>
- 55°C	110% of Rated
+ 25°C	100% of Rated
+ 125°C	80% of Rated

The test current shall be maintained for 30 minutes after the temperature of each fuse has stabilized, but shall not be applied for less than 1.5 hours. It may be assumed that the temperature has stabilized when three consecutive temperature readings taken at 10 minute intervals show no rise in temperature. The temperature of the fuse body shall be measured by thermocouples (wire size 28 to 32 AWG).

5.8.8 Terminal Strength. Fuses shall be tested in accordance with Method 211 of MIL-STD-202. The following exceptions shall apply:

- a) Test Condition - Test Condition A (5 lbs pull) applying the force axially to each lead wire individually, then Test Condition C (1 lb force) applying three bends to each wire terminal.
- b) Method of Holding - The fuse body shall be held by means other than rigid clamping to prevent stresses from being transferred to the fuse element.
- c) Measurements - DC resistance measurements shall be taken before and after exposure in accordance with 5.8.2.

5.8.9 Moisture Resistance (Group C / Qualification Only). Fuses shall be tested in accordance with Method 106 of MIL-STD-202. The following exceptions shall apply:

- a) Mounting - Normal mounting means on a noncorrosive metal panel positioned 15 degrees from the vertical with the terminals down.
- b) Polarizing voltage shall be 100 volts DC.
- c) Steps 7a and 7b are not applicable.
- d) Measurements - DC resistance measurements shall be taken before and after the exposure in accordance with 5.8.2.

5.8.10 Shock (Group C / Qualification Only). Fuses shall be tested in accordance with Method 213 of MIL-STD-202. The following details and exceptions shall apply:

- a) Mounting - Fuses shall be securely fastened to the table of the shock machine to prevent relative motion between the fuses and the table.
- b) Test Condition - F (except 1500G, 0.5 milliseconds, half-sine)
- c) Loading during Test - Rated DC current on half of the samples tested.
- d) Number of Shocks - Three shocks in each direction of three mutually perpendicular axes (18 shocks total).
- e) Measurements - DC resistance measurements shall be taken before and after the shock exposure in accordance with 5.8.2.

AEM, Inc.		11525 SORRENTO VALLEY RD SAN DIEGO, CA 92121-1306.		TITLE P800L SPECIFICATION	
NUMBER	P800L	REVISION	C	ECN	2117
				SHEET 13 of 21	

5.8.11 Vibration (Group C / Qualification Only). Fuses shall be tested in accordance with Method 204 of MIL-STD-202. The following details and exceptions shall apply:

- a) Mounting - Fuses shall be securely fastened to the table of the vibration machine to prevent relative motion between the fuses and the table.
- b) Test Level - Sinusoidal vibration from 5 to 3000 hertz, 0.4 inch double amplitude or 30G's peak, whichever is less.
- c) Sweep Rate - Approximately 1/2 octave per minute.
- d) Test Duration - 12 hours total (4 hours in each of three major axes).
- e) Loading during Testing - Rated DC current on half of the samples tested.
- f) Measurements - DC resistance measurements shall be taken before and after the vibration exposure in accordance with 5.8.2.

5.8.12 Resistance to Soldering Heat (Group C / Qualification Only). Fuses shall be tested in accordance with Method 210 of MIL-STD-202. The following exceptions shall apply:

- a) The leads shall have the gold removed by single or double dipping into a flowing or nonflowing hot solder of sufficient volume to assure complete gold removal. Both leads shall be dipped in R flux per MIL-F-14256 for a period of 5 +/- 2 seconds, after which they shall be pre-tinned by immersion into solder for 3 to 5 seconds. The solder shall be maintained at 260°C +/- 5°C. The leads shall be immersed to within .050 inches of the body of the fuse.
- b) Test Condition B.
- c) Cooling Time - Five minutes minimum.
- d) Measurements - DC resistance measurements shall be taken before and after soldering heat exposure in accordance with 5.8.2.
- e) Examination after Test - Fuses shall be examined at a 7X magnification for evidence of mechanical damage.

5.8.13 Low Temperature Operation (Group C / Qualification Only). Fuses shall be mounted by their terminals in sockets and placed in a low temperature chamber. The chamber temperature shall be lowered gradually to -55°C +0/-3°C within a period of 1 hour. After stabilizing at the low temperature for a period of 1 hour, rated DC current shall be applied to the fuses for a period of 4 +1/-0 hours while at the low temperature. The chamber shall then be gradually raised to room temperature within a 4 hour period and maintained at room temperature for a period of 8 hours minimum. After this time, the DC current shall be removed from the fuses and the fuses removed from the chamber. The DC resistance of the fuses shall be measured before and after the test in accordance with 5.8.2.

5.8.14 Life (2000 Hours, Group C / Qualification Only). Fuses shall be mounted by their terminals in sockets and placed in a chamber at +125°C +3/-0°C ambient. The fuses shall be electrically connected to a DC source supplying 64 percent of the +25°C rated current. The current source shall supply an open circuit voltage equal to the voltage rating of the fuses. The fuses shall remain in the chamber at the specified current for 2000 +/- 8 hours. The electrical circuit shall provide a suitable indicator, which shall be monitored daily during the length of the life test, to identify failure (blowing) of any fuse. The time of failure shall be recorded to the nearest +/-12 hours and the blown fuse replaced with a short circuit for the remainder of the test. The DC resistance of the fuses shall be measured before and after the test in accordance with 5.8.2.

AEM, Inc.		11525 SORRENTO VALLEY RD SAN DIEGO, CA 92121-1306.		TITLE P800L SPECIFICATION
NUMBER	P800L	REVISION	C	ECN 2117
				SHEET 14 of 21

5.8.15 Overload Current. Fuses shall be subjected to the applicable percent of DC current (250%, 400% or 600%) specified in Table VI. For Group B and Group C inspections, the fuses shall be tested while at case temperatures of +25°C to +35°C. For Qualification inspection (Subgroup II, Table V) and Group C inspection (Subgroup II, Table IV) the fuses shall be divided equally and tested at -55°C to -60°C, at +25°C to +35°C, and at +125°C to +130°C. The low impedance source shall be adjusted to supply an open circuit voltage equal to the rating of the fuse. The time to "blow" (the interval measured from the application of the current to the time the current drops below the rating of the fuse) shall be measured for each fuse. Each fuse shall remain in the test circuit for 1 minute after the fuse opens to check for restrike conditions. The maximum clearing I²T shall be determined using an oscillogram showing the current trace. The determination shall be made by application of Simpson's rule. A recommended test circuit is shown in Figure 2.

5.8.16 Resistance after Firing. The open resistance of the "blown" fuse shall be measured by applying rated DC voltage across the terminals of the fuse. The resistance value shall be taken after a one-minute application of the test voltage.

5.8.17 Thermal Vacuum (Qualification Only). Fuses shall be mounted in suitable mount sockets. The fuses shall then be placed in a vacuum chamber and the chamber evacuated to a pressure of 5 X 10⁻⁵ torr maximum. The temperature of the fuse mount shall be controlled such that the temperature of the fuses, measured with a thermocouple mounted on the fuse body, is maintained at +125 +/- 3°C for a period of 48 +4/-0 hours, while 90% of the +25°C rated current is flowing through each fuse. At the end of the 48 hour exposure and while the fuses are at the test temperature and pressure, half of the samples shall be given an overload current at 400 percent of their rated current using the procedure specified in 5.8.15. The fuses shall then be removed from the chamber and the remaining fuses (not blown) measured for DC resistance in accordance with 5.8.2.

5.8.18 Salt Spray Corrosion (Group C / Qualification Only). Fuses shall be tested in accordance with Method 101 of MIL-STD-202. The following details shall apply:

- a) Five percent salt solution.
- b) Test Condition B.
- c) Following the drying period, the fuses shall be subjected to 100 percent of rated current for 1 hour.
- d) Following the test the fuses shall be examined for compliance with 4.8.17.

5.8.19 Outgassing (Qualification Only). The fuses or fuse materials shall be tested as specified in ASTM E595.

5.8.20 Short Circuit Interrupt (Group C / Qualification Only). Fuses shall be placed in a DC test circuit capable of supplying a minimum of 1000 amperes. The test circuit shall be made using appropriate generating equipment as a source of power and with the rate of current rise for the test circuit adjusted for at least 3.25 X 10⁶ amperes per second. The open circuit voltage of the test circuit shall be adjusted to a value equal to the maximum rating of the fuse to be tested.

AEM, Inc.		11525 SORRENTO VALLEY RD SAN DIEGO, CA 92121-1306.		TITLE P800L SPECIFICATION
NUMBER	P800L	REVISION	C	ECN 2117
				SHEET 15 of 21

6. APPLICATIONS

6.1 Parallel Operation. Fuses may be used in parallel operation to gain current-carrying capability. When fuses are to be utilized in parallel configurations, the fuses should be procured as matched sets. The requirements for matched set fuses are indicated below.

- a) Each matched set shall consist of two or more fuses.
- b) Matched set fuses shall be from the same manufacturing lot (same voltage and current rating).
- c) Matched set fuses shall be created by matching individual voltage drops within the set to within 1% (highest to lowest within individual set). The voltage drop values used for matching shall be extracted from the voltage drops taken following the burn-in period.
- d) Matched set fuses shall be marked in accordance with paragraph 4.7 except that the part number will be modified to indicate the set amperage value and the number of fuses within the set (see matched set examples below). Additionally, matched set serial label shall be placed on the top of each part. Matched set serial labels shall consist of a unique number for each fuse set, followed by a unique letter for each fuse within the set (i.e., 001A, 001B, 001C, 001D; 002A, 002B, 002C, 002D; etc.). Matched fuses may exceed the maximum height dimension by .010 inches as a result of the match set label.
- e) Matched set fuses shall be packaged together, separate from other matched set fuses.
- f) Data generated by the matching requirement shall be included with the standard Group A and B Data Package.
- g) The number of fuses within the matched set shall be specified on the purchase order.

Matched-Set Examples:

P800L-72-20.0-M2 (two P800L-72-10.0 supplied as a matched set forming a 20 amp equivalent fuse)

P800L-72-30.0-M2 (two P800L-72-15.0 supplied as a matched set forming a 30 amp equivalent fuse)

P800L-72-60.0-M4 (four P800L-72-15.0 supplied as a matched set forming a 60 amp equivalent fuse)

Part Marking Note:

- 1. Front side of fuse identified with matched set part number as indicated above.
- 2. Backside of fuse identified as specified in 4.7 (except that individual fuse rating is also noted).

6.2 Installation. Fuses may be mounted directly onto a printed circuit board or in crimp type receptacles. Bending or twisting of the leads should not be done without mechanically supporting the leads at the exit of the fuse body.

AEM, Inc.		11525 SORRENTO VALLEY RD SAN DIEGO, CA 92121-1306.		TITLE P800L SPECIFICATION	
NUMBER	P800L	REVISION	C	ECN	2117
				SHEET 16 of 21	

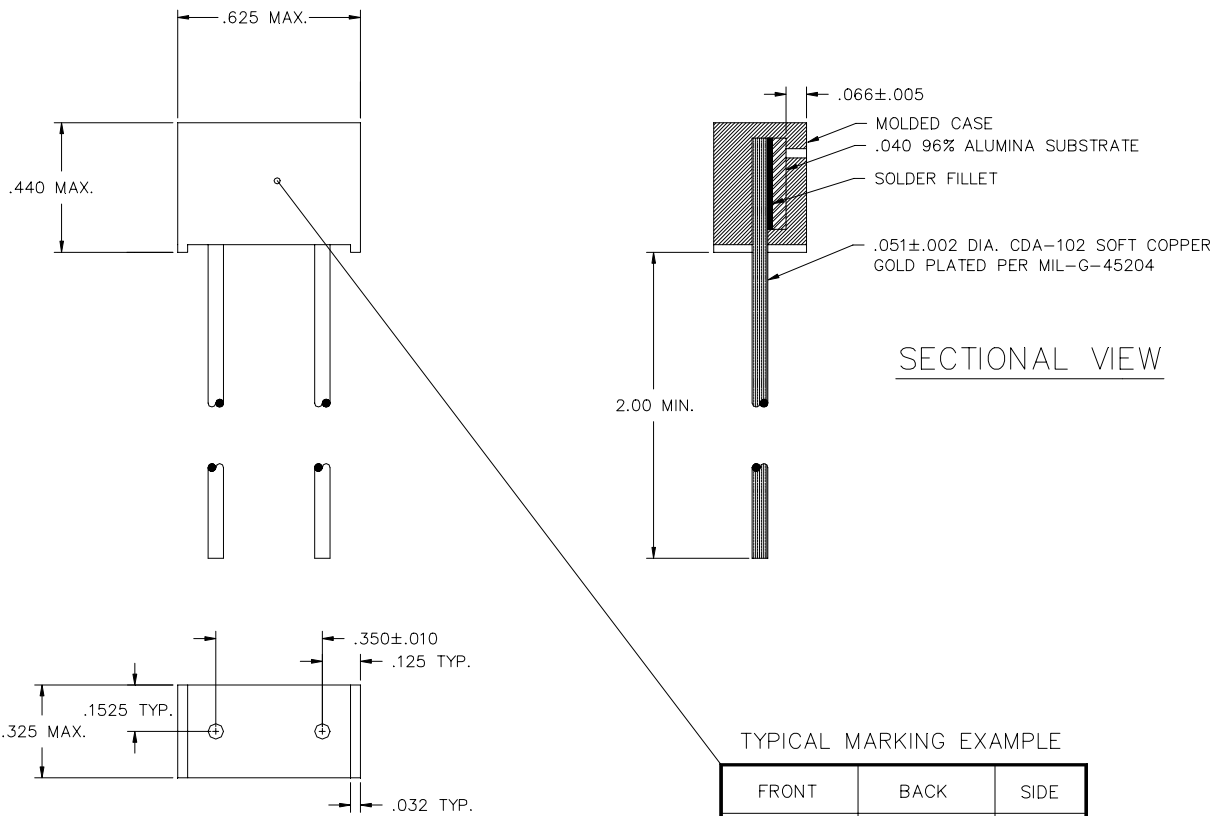

1. Dimensions are in inches.
2. Contour optional within dimensional limits.
3. Lead wire terminals shall be CDA-102 Copper.
4. Brady type labels for serial number identification shall be overcoated with Shell Epon overcoat or equivalent.
5. Maximum weight shall be 5.0 grams.
6. Minimum marking shall be abbreviated:

Pin No.: P800L
 Current Rating: 7.5A (ex.)
 Voltage Rating: 72 VDC
 Lot Code: C-XXXX
 AEM Logo: AEM
 Serial No.: 123456 (ex.)

FIGURE 1. DIMENSIONS, CONSTRUCTION AND MARKING.

AEM, Inc.	11525 SORRENTO VALLEY RD SAN DIEGO, CA 92121-1306.	TITLE P800L SPECIFICATION
NUMBER P800L	REVISION C	ECN 2117
		SHEET 17 of 21

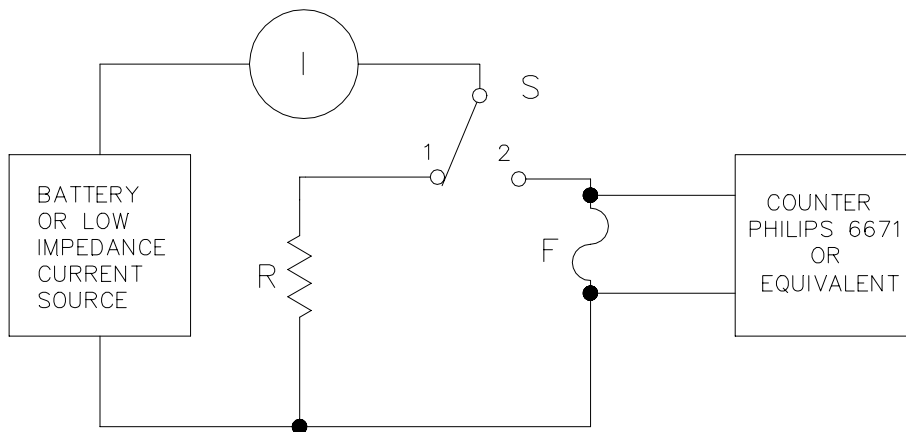

NOTES:

- R = Non-inductive resistor equal to the ohmic value of the fuse being tested.
- S = Non-bounce high current switch.
- I = Current adjusted to percent overload with switch in position 1.
- F = Current limiting fuse under test.

FIGURE 2. OVERLOAD CURRENT TEST CIRCUIT.

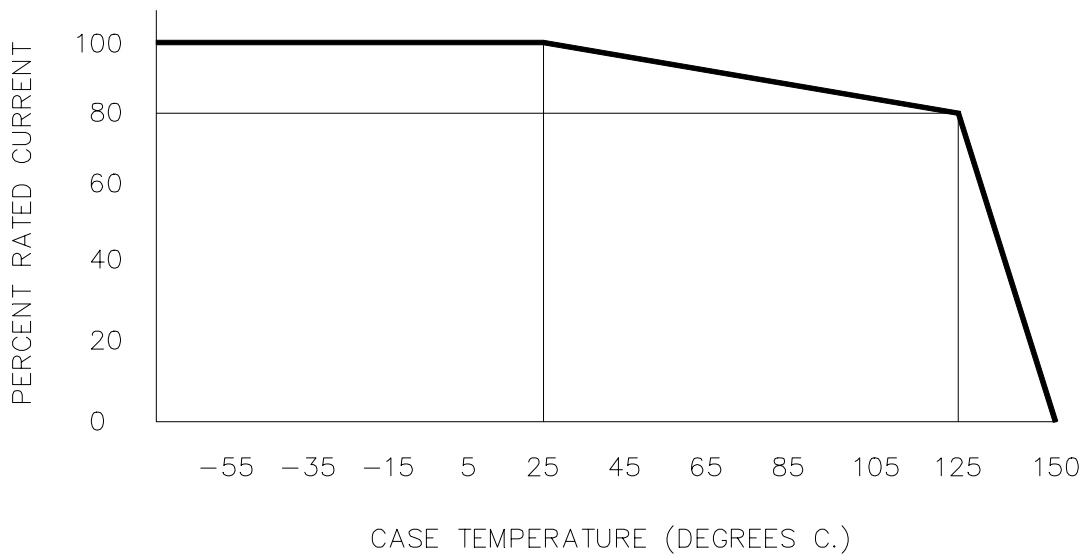
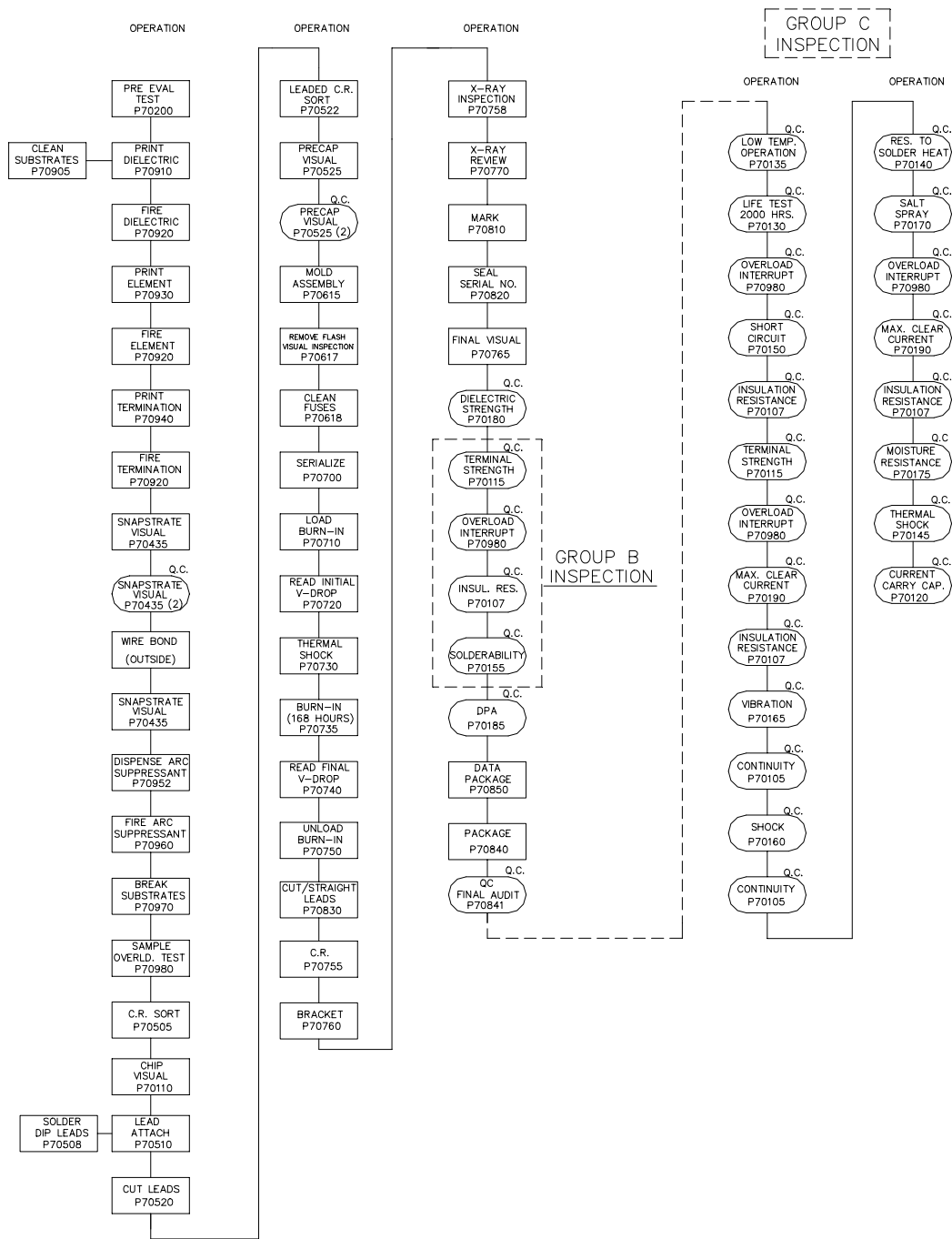

FIGURE 3. CURRENT DERATING LIMITS.

AEM, Inc.		11525 SORRENTO VALLEY RD SAN DIEGO, CA 92121-1306.		TITLE P800L SPECIFICATION	
NUMBER P800L		REVISION C	ECN 2117	SHEET 18 of 21	



Notes:

1. FLOW CHART IN ACCORDANCE WITH AEM P800L AND MIL-PRF-23419/12 SPECIFICATIONS.
2. QC WILL AUDIT PER MIL-STD-105, LEVEL II, AT 1% AQL.

FIGURE 4. OPERATIONS FLOW CHART.

AEM, Inc.		11525 SORRENTO VALLEY RD SAN DIEGO, CA 92121-1306.		TITLE P800L SPECIFICATION	
NUMBER P800L		REVISION C	ECN 2117	SHEET 19 of 21	

DOCUMENT CHANGE NOTICE

<u>REV. LETTER</u>	<u>REV. DATE</u>	<u>PAGE</u>	<u>CHANGE ITEM</u>	<u>APPROVAL</u>
A	10-04-95	N/A	Issued new drawing	J.M. 10/95
B	02-08-99	All	Added "Group C / Qualification Only" for all Group C / Qualification Test paragraphs	J.M. 2/96
		3	Revised 4.3 to indicate 72 VDC	
		4	Revised 4.6 and 4.8.4	
		5	Revised 4.8.8.1 to indicated 20 samples minimum	
		6	Revised 4.9	
		7	Revised 5.3, 5.4 and 5.7.5	
		8	Revised Table II (position of DWV Test) and added PDA note 1	
		10	Revised Table IV to follow Mil-F-23419/12	
		11	Revised Table IV to follow Mil-F-23419/12	
		13	Revised 5.8.1 to list AEM procedures	
		13	Revised 5.8.4 for part spacing	
		15	Revised 5.8.10 and 5.8.11	
		15	Revised 5.8.15 to include Group C	
		20	Revised flow chart per Mil-F-23419/12	
C	2-4-00	All	Re-typed in "Word" format	J.M. 2-4-00
		2	Revised 1.1 to indicate operating temperature range of -55°C to +125°C (previously stated -55°C to +150°C)	
		2	Revised 3.1 to indicate MIL-PRF-23419 (previously stated MIL-F-23419)	
		3	Removed reference to P600L-M Specification in 3.1	
		3	Removed reference to Ryton R-4 in 4.2.2	
		5	Revised 4.8.18 to indicate "CVCM" (previously stated "VCM")	

AEM, Inc.		11525 SORRENTO VALLEY RD SAN DIEGO, CA 92121-1306.		TITLE
NUMBER	P800L	REVISION	C	ECN 2117
				SHEET 20 of 21

DOCUMENT CHANGE NOTICE

<u>REV. LETTER</u>	<u>REV. DATE</u>	<u>PAGE</u>	<u>CHANGE ITEM</u>	<u>APPROVAL</u>
C	2-04-00	7	Revised Table II to reference "MIL-PRF-23419 (previously stated "MIL-F-23419)	
		10	Corrected Table V to include Short Circuit Interrupt Test in Subgroup III (as required by MIL-PRF-23419)	
		12	Revised 5.8.2 to reference Keithly Model 580 (previously reference Valhalla Model 4300B)	
		16	Revised 6.1 to indicate all matching requirements (electrical/marketing/documentation) as previously noted in P600L-M Specification	

AEM, Inc.	11525 SORRENTO VALLEY RD SAN DIEGO, CA 92121-1306.	TITLE P800L SPECIFICATION	
NUMBER P800L	REVISION C	ECN 2117	SHEET 21 of 21