



AEM, INC.

11525 Sorrento Valley Rd.
San Diego, California 92121
(858) 481- 0210

SPECIFICATION SHEET

CURRENT LIMITING FUSE

1206 SURFACE MOUNT MODEL (CHIP)

REVISION:	A	B	C	D						
DATE:	2/99	10/01	5/02	9/03						
DRAWN:	Jeff Montgomery					Drawing: SM1206				
CHECKED:	M. Van Linge / M. Esmende									
APPROVED:	Jeff Montgomery									
ECN:	2136					SHEET 1 OF 18				

1. SCOPE

1.1 Scope. This specification establishes the requirements for thick film current limiting 1206 chip fuses. Fuses described in this document are designed and manufactured for high reliability applications based on guaranteed blow limits. These fuses are intended for use in direct (DC) and alternating current (AC) circuits and are capable of operation over a temperature range of -55°C to +125°C ambient including high vacuum environments.

2. LOT ACCEPTANCE TESTING

2.1 Lot Acceptance Testing. This specification provides for two acceptance levels for the procurement of the fuses. The degree of testing and associated documentation can be specified as appropriate to the end use of the fuses. Regardless of the acceptance level specified, the inherent quality and reliability of the fuses will remain constant. The acceptance levels with the applicable inspection required are indicated in Table I.

TABLE I. LOT ACCEPTANCE LEVEL.

LOT ACCEPTANCE LEVEL	INSPECTION TO BE PERFORMED		
	GROUP A	GROUP B	GROUP C
LAT 2	X	X	
LAT 1	X	X	X

3. APPLICABLE DOCUMENTS

3.1 Issues of Documents. The following specifications, standards and handbooks form a part of this specification to the extent specified herein. In the event of a conflict between the documents referenced herein and this specification, this specification governs.

SPECIFICATIONS

MIL-PRF-23419: General Specification for Instrument Type Fuses.

MIL-F-14256: Flux, Soldering, Liquid (Rosin Base).

STANDARDS

MIL-STD-202: Test Methods for Electronic and Electrical Component Parts.

MIL-STD-790: Reliability Assurance Program for Electronic Parts Specifications.

MIL-STD-45662: Calibration System Requirements.

AEM, Inc.	11525 SORRENTO VALLEY RD SAN DIEGO, CA 92121-1306.	TITLE SM1206 CURRENT LIMITING FUSE
NUMBER SM1206	REVISION D	ECN 2136 SHEET 2 of 18

OTHERS

ASTM E595:	Materials from Outgassing in a Vacuum Environment, Total Mass Loss and Collected Volatile Condensable, Standard Test Method for.
P70435	AEM Operation for Snapstrate Visual (Element/Termination).
P71248	AEM Operation for Final Visual Inspection of Chip Fuses.

4. REQUIREMENTS

4.1 Qualification. Fuses manufactured in accordance with this document shall be capable of passing the qualification requirements specified in Table V and section 4 of this document.

4.2 Materials, Design and Construction. The materials, design and construction of the fuses shall be as specified herein. Marking color (if applicable) and arc suppressant glass color are noted in Table VII.

4.2.1 Terminals. The base terminations shall be silver with plated nickel and a final finish of Sn90/Pb10 solder coating. Under no circumstances shall the tin percentage exceed 97%.

4.3 Voltage Rating. The voltage ratings for fuses specified herein are 24 and 32 volts DC. The applicable voltage ratings are specified in Table VI.

4.4 Current Rating. The current rating is the maximum amperes that the fuse will carry at a substrate temperature of +25°C without degradation. The applicable current ratings are specified in Table VI.

4.5 Temperature Rating. The temperature rating for fuses specified herein is -55°C to +150°C nonoperating. The maximum operating temperature shall not exceed a substrate temperature of +125°C. The temperature derating curve is given in Figure 3.

4.6 Resistance Rating. The cold resistance of the fuses shall be as specified in Table VI when measured in accordance with 5.8.2.

4.7 Performance.

4.7.1 Thermal Shock. When fuses are tested in accordance with 5.8.3 herein, they shall show no electrical or mechanical damage.

4.7.2 Current-Carrying Capacity. When fuses are tested in accordance with 5.8.6, they shall show no evidence of mechanical damage and shall carry the current as specified without electrical failure. The temperature rise of the substrate shall at no point rise more than +85°C above the ambient air temperature.

4.7.3 Termination Strength. When fuses are tested in accordance with 5.8.7, the end terminations shall not break or loosen. The cold resistance values shall not change by more than 10 percent.

4.7.4 Thermal Vacuum (Qualification Only). When fuses are tested in accordance with 5.8.16, they shall not open circuit during the application of derated DC current nor shall there be evidence of arcing or mechanical damage after the test. Fuses that are subjected to the 400 percent overload current test shall "blow" within the time period specified (see Table VI). The cold resistance values of those fuses not subjected to the overload current shall not change by more than 10 percent when measured after thermal vacuum exposure.

AEM, Inc.	11525 SORRENTO VALLEY RD SAN DIEGO, CA 92121-1306.	TITLE SM1206 CURRENT LIMITING FUSE
NUMBER SM1206	REVISION D	ECN 2136
		SHEET 3 of 18

4.7.5 Overload Current.

4.7.5.1 Overload Current Characterization. Each fuse lot shall be sampled to assure that the blow times fall within the limits of Table VI. Each lot shall be truncated to form an inspection lot based upon the cold resistance measured after thermal shock. The manufacturer shall blow samples (a minimum of 20 samples total) selected from the extremes of the truncated population to insure that their blow times are within the specification. The results of this procedure shall be included in the "Group A Data" with the lot data package.

4.7.5.2 Overload Current. Fuses selected from a truncated distribution shall be tested in accordance with 5.8.14. The clearing times and the maximum I^2t shall be as specified in Table VI. After clearing, the circuit shall remain open without closing again during a one-minute period. The let through energy during the one-minute period shall be included in the calculation of I^2t . The blown fuses shall meet the resistance after firing test of 4.7.6.

4.7.6 Resistance after Firing. When blown fuses are tested in accordance with 5.8.15, the minimum resistance shall be 1 megohm.

4.7.7 Moisture Resistance (Group C / Qualification Only). When fuses are tested in accordance with 5.8.8, there shall be no evidence of mechanical damage or excessive corrosion of the terminations. The resistance of the fuses shall not change by more than 15 percent as a result of the moisture exposure.

4.7.8 Shock (Group C / Qualification Only). When fuses are tested in accordance with 5.8.9, there shall be no evidence of mechanical damage and the fuse resistance shall not change by more than 10 percent.

4.7.9 Vibration (Group C / Qualification Only). When fuses are tested in accordance with 5.8.10, there shall be no evidence of mechanical damage and the fuse resistance shall not change by more than 10 percent.

4.7.10 Low Temperature Operation (Group C / Qualification Only). When fuses are tested in accordance with 5.8.12, they shall not open circuit and the fuse resistance shall not change by more than 10 percent.

4.7.11 Life (2000 Hours, Group C / Qualification Only). When fuses are tested in accordance with 5.8.13, they shall not open circuit and the fuse resistance shall not change by more than 10 percent.

4.7.12 Resistance to Soldering Heat. When fuses are tested in accordance with 5.8.11, there shall be no mechanical damage and the fuse resistance shall not change by more than 10 percent.

4.7.13 Solderability. Fuses shall meet the solderability requirements specified in MIL-STD-202, Method 208.

4.7.14 Salt Spray (Group C / Qualification Only). When fuses are tested in accordance with 5.8.17, there shall be no evidence of excessive corrosion. Excessive corrosion is defined as that which interferes with the electrical or mechanical performance. There shall be no mechanical damage and the fuse resistance shall not change by more than 10 percent.

4.7.15 Outgassing. When fuses are tested in accordance with 5.8.18, the materials shall meet the following requirements:

- a) Total mass loss (TML) - Shall not exceed 1.0 percent.
- b) Collected volatile condensable material (CVCM) - Shall not exceed 0.1 percent.

4.7.16 Short Circuit Interrupt (Group C / Qualification Only). When fuses are tested in accordance with 5.8.19, the resistance after short circuit testing shall be at least 1 megohm.

AEM, Inc.	11525 SORRENTO VALLEY RD SAN DIEGO, CA 92121-1306.	TITLE SM1206 CURRENT LIMITING FUSE
NUMBER SM1206	REVISION D	ECN 2136
		SHEET 4 of 18

4.7.17 Pre-Cap Inspection (Group A). Prior to arc suppressant application, the fuses shall be inspected at 10X magnification. Inspection criteria are outlined in AEM Operation P70435.

4.8 Workmanship. Fuses shall be manufactured and processed in such a manner as to ensure that uniform quality is established. All fuses shall be free of defects that will affect usable life or reliability.

4.9 Traceability Requirements. A unique C-lot number (C-XXXX) will be assigned to each fuse lot. The C-lot number will be referenced in all Group A and B screening data and will also appear on the reel label if the fuses are to be provided with tape and reel option.

5. QUALITY ASSURANCE PROVISIONS

5.1 Classification of Inspection. The inspection of fuses procured to the requirements of this specification shall be classified as follows:

- a) Qualification Inspection (paragraph 5.6) when specified on the purchase order.
- b) Acceptance Inspection (paragraph 5.7).

5.2 Reliability Assurance Program. AEM shall ensure that a reliability assurance program is established and maintained in accordance with MIL-STD-790.

5.3 Test Equipment and Inspection Facilities. AEM shall establish and maintain a calibration system in accordance with MIL-STD-45662.

5.4 Acceptance Inspection Reports. AEM shall supply with each shipment of fuses the following minimum data:

- a) Non-standard test reports as required by the purchase order.
- b) Certification of Conformance signed by Quality Assurance Manager.
- c) Group A and B data.
- d) Group C data, if required by the purchase order, shall be shipped at the completion of Group C inspection.

5.5 Inspection Conditions and Methods. Unless otherwise specified in this document, inspections shall be conducted at room ambient environments of +25°C +/- 5°C and the maximum relative humidity shall be 75 percent.

5.6 Qualification Inspection.

5.6.1 Qualification Samples. Samples submitted to qualification inspection shall be representative of the normal production. A sample of 48 fuses representing the lowest, middle, and highest cold resistance values within the truncated distribution shall be submitted for qualification inspection. At the completion of Subgroup I inspection, the 48 samples shall be divided into the subgroups and quantities shown in Table V. Each subgroup shall have approximately equal representation of the fuse cold resistance values.

5.7 Acceptance Inspection.

5.7.1 Inspection of Fuses for Delivery. Inspection of fuses for delivery against a purchase order shall consist of the tests listed in Table I.

5.7.2 Inspection Lot. An inspection lot shall consist of one amperage rating of one lot date code.

AEM, Inc.	11525 SORRENTO VALLEY RD SAN DIEGO, CA 92121-1306.	TITLE SM1206 CURRENT LIMITING FUSE
NUMBER SM1206	REVISION D	ECN 2136
		SHEET 5 of 18

5.7.3 Group A Inspection. Group A inspection shall consist of the tests listed in Table II and shall be conducted in the order indicated.

5.7.4 Group B Inspection. Group B inspection shall consist of the tests listed in Table III and shall be conducted in the order indicated. All fuses submitted to Group B inspection shall have successfully met all electrical requirements of the Group A inspection (Visual rejects may be utilized for Group B inspection).

5.7.5 Group C Inspection. Group C inspection, when required by the purchase order, shall consist of the tests listed in Table IV. The fuses submitted for Group C inspection shall have met Group A and Group B inspection requirements as part of the inspection lot from which they were taken. Group C inspection must be completed within 150 days after the completion of Group B inspection.

AEM, Inc.	11525 SORRENTO VALLEY RD SAN DIEGO, CA 92121-1306.	TITLE SM1206 CURRENT LIMITING FUSE	
NUMBER SM1206	REVISION D	ECN 2136	SHEET 6 of 18

TABLE II. GROUP A INSPECTION.

EXAMINATION OR TEST	REQUIREMENT PARAGRAPH	METHOD PARAGRAPH	NUMBER OF UNITS SPECIFIED	NUMBER OF DEFECTIVES ALLOWED
PRE-CAP INSPECTION	4.7.17		100%	N/A
THERMAL SHOCK	4.7.1	5.8.3	100%	N/A
COLD RESISTANCE	4.6	5.8.2	100%	N/A
OVERLOAD CURRENT CHARACTERIZATION	4.7.5.1	5.8.14	20 PIECES MINIMUM	N/A
VISUAL AND MECHANICAL EXAMINATION	4.2, 4.2.1, 4.8	5.8.1	100%	N/A

TABLE III. GROUP B INSPECTION.

44 Samples Required.

EXAMINATION OR TEST	REQUIREMENT PARAGRAPH	METHOD PARAGRAPH	NUMBER OF UNITS SPECIFIED	NUMBER OF DEFECTIVES ALLOWED
SUBGROUP I (20 UNITS)				
OVERLOAD CURRENT (+25°C)	4.7.5.2	5.8.14	20	0
RESISTANCE AFTER FIRING	4.7.6	5.8.15	20	0
SUBGROUP II (8 UNITS)				
SOLDERABILITY	4.7.13	MIL-STD-202, METHOD 208	8	0
SUBGROUP III (4 UNITS)				
RESISTANCE TO SOLDERING HEAT	4.7.12	5.8.11	4	0
SUBGROUP IV (4 UNITS)				
TERMINATION STRENGTH	4.7.3	5.8.7	4	0
SUBGROUP V (8 UNITS)				
CURRENT-CARRYING CAPACITY (+25°C)	4.7.2	5.8.6	8	0

AEM, Inc.	11525 SORRENTO VALLEY RD SAN DIEGO, CA 92121-1306.	TITLE SM1206 CURRENT LIMITING FUSE	
NUMBER SM1206	REVISION D	ECN 2136	SHEET 7 of 18

TABLE IV. GROUP C INSPECTION.**34 Samples Required.**

EXAMINATION OR TEST	REQUIREMENT PARAGRAPH	METHOD PARAGRAPH	NUMBER OF UNITS SPECIFIED	NUMBER OF DEFECTIVES ALLOWED
SUBGROUP I (16 UNITS)				
LOW TEMPERATURE OPERATION	4.7.10	5.8.12	12	0
LIFE (2000 HOURS)	4.7.11	5.8.13	12	0
OVERLOAD CURRENT (+25°C)	4.7.5.2	5.8.14	12	
RESISTANCE AFTER FIRING	4.7.6	5.8.15	12	0
SHORT CIRCUIT INTERRUPT	4.7.16	5.8.19	4	0
RESISTANCE AFTER FIRING	4.7.6	5.8.15	4	0
SUBGROUP II (6 UNITS)				
OVERLOAD CURRENT	4.7.5.2	5.8.14	6	0
RESISTANCE AFTER FIRING	4.7.6	5.8.15	6	0
SUBGROUP III (4 UNITS)				
VIBRATION	4.7.9	5.8.10	4	0
SHOCK	4.7.8	5.8.9	4	0
RESISTANCE TO SOLDERING HEAT	4.7.12	5.8.11	4	0
SUBGROUP IV (4 UNITS)				
SALT SPRAY	4.7.14	5.8.17	4	0
OVERLOAD CURRENT (+25°C)	4.7.5.2	5.8.14	4	0
RESISTANCE AFTER FIRING	4.7.6	5.8.15	4	0
SUBGROUP V (4 UNITS)				
MOISTURE RESISTANCE	4.7.7	5.8.8	4	0
THERMAL SHOCK	4.7.1	5.8.3	4	0
CURRENT-CARRYING CAPACITY (+25°C)	4.7.2	5.8.6	4	0

AEM, Inc.	11525 SORRENTO VALLEY RD SAN DIEGO, CA 92121-1306.	TITLE SM1206 CURRENT LIMITING FUSE	
NUMBER SM1206	REVISION D	ECN 2136	SHEET 8 of 18

TABLE V. QUALIFICATION INSPECTION.

48 Samples Required.

EXAMINATION OR TEST	REQUIREMENT PARAGRAPH	METHOD PARAGRAPH	NUMBER OF UNITS SPECIFIED	NUMBER OF DEFECTIVES ALLOWED
SUBGROUP I (48 UNITS)				
VISUAL AND MECHANICAL EXAMINATION	4.2, 4.2.1, 4.8	5.8.1	48	0
RESISTANCE	4.6	5.8.2	48	0
SUBGROUP II (6 UNITS)				
SOLDERABILITY	4.7.13	MIL-STD 202 METHOD 208	6	0
OVERLOAD CURRENT (HIGH/LOW TEMPS.)	4.7.5.2	5.8.14	6	0
RESISTANCE AFTER FIRING	4.7.6	5.8.15	6	0
SUBGROUP III (24 UNITS)				
LOW TEMPERATURE OPERATION	4.7.10	5.8.12	12	0
LIFE (2000 HOURS)	4.7.11	5.8.13	12	0
OVERLOAD CURRENT (+25°C)	4.7.5.2	5.8.14	12	0
RESISTANCE AFTER FIRING	4.7.6	5.8.15	12	0
THERMAL VACUUM (SEPARATE SAMPLE)	4.7.4	5.8.16	8	0
OVERLOAD CURRENT (400%)	4.7.5.2	5.8.16	4	0
RESISTANCE AFTER FIRING	4.7.6	5.8.15	4	0
SHORT CIRCUIT INTERRUPT (SEPARATE SAMPLE)	4.7.16	5.8.19	4	0
RESISTANCE AFTER FIRING	4.7.6	5.8.15	4	0
SUBGROUP IV (4 UNITS)				
VIBRATION	4.7.9	5.8.10	4	0
SHOCK	4.7.8	5.8.9	4	0
SUBGROUP V (4 UNITS)				
SALT SPRAY	4.7.14	5.8.17	4	0
OVERLOAD CURRENT (+25°C)	4.7.5.2	5.8.14	4	0
RESISTANCE AFTER FIRING	4.7.6	5.8.15	4	0
SUBGROUP VI (4 UNITS)				
OUTGASSING	4.7.15	5.8.18	*(AS REQUIRED)	0
MOISTURE RESISTANCE	4.7.7	5.8.8	4	0
THERMAL SHOCK	4.7.1	5.8.3	4	0
RESISTANCE TO SOLDERING HEAT	4.7.12	5.8.11	4	0
CURRENT-CARRYING CAPACITY (+25°C)	4.7.2	5.8.6	4	0
OVERLOAD CURRENT (+25°C)	4.7.5.2	5.8.14	4	0
RESISTANCE AFTER FIRING	4.7.6	5.8.15	4	0
SUBGROUP VII (6 UNITS)				
TERMINAL STRENGTH	4.7.3	5.8.7	6	0

* Outgassing sample size dependent on testing laboratory.

AEM, Inc.		11525 SORRENTO VALLEY RD SAN DIEGO, CA 92121-1306.		TITLE SM1206 CURRENT LIMITING FUSE	
NUMBER	SM1206	REVISION	D	ECN	2136
			SHEET 9 of 18		

TABLE VI. ELECTRICAL AND MECHANICAL REQUIREMENTS.

FUSE PART NUMBER / RATINGS			COLD RESISTANCE (OHMS) /1		OVERLOAD INTERRUPT TIME (SECONDS) /2/3/5			MAXIMUM I ² T (A ² SEC)
PART NUMBER	MAXIMUM VOLTAGE (VDC)	CURRENT RATING (AMPS)	MINIMUM (OHMS)	MAXIMUM (OHMS)	250% NOMINAL RATING	400% NOMINAL RATING	600% NOMINAL RATING	
SM1206-32-1/4	32	0.250	1.500	2.500	.005-60.0	.0005-.015	.00005-.003	NOTE 4
SM1206-32-3/8	32	0.375	1.125	1.875	.005-60.0	.0005-.015	.00005-.003	NOTE 4
SM1206-32-1/2	32	0.500	0.450	0.750	.005-10.0	.0005-.015	.00005-.003	NOTE 4
SM1206-32-3/4	32	0.750	0.198	0.331	.005-10.0	.0005-.015	.00005-.003	NOTE 4
SM1206-32-1.0	32	1.000	0.120	0.190	.005-5.0	.0005-.010	.0001-.003	NOTE 4
SM1206-32-1.5	32	1.500	0.0825	0.1375	.005-3.0	.0005-.010	.0001-.003	NOTE 4
SM1206-32-2.0	32	2.000	0.0410	0.0680	.005-3.0	.0005-.010	.0001-.003	NOTE 4
SM1206-32-3.0	32	3.000	0.0240	0.0400	.005-1.0	.0005-.010	.0001-.003	NOTE 4
SM1206-24-4.0	24	4.000	0.0184	0.0276	.005-1.0	.0005-.010	.0001-.003	NOTE 4
SM1206-24-5.0	24	5.000	0.0120	0.0200	.005-1.0	.0005-.010	.0001-.003	NOTE 4
SM1206-24-6.0	24	6.000	0.0105	0.0175	.010-1.0	.0005-.010	.0001-.003	NOTE 4
SM1206-24-7.0	24	7.000	0.0096	0.0144	.010-1.0	.0005-.010	.0001-.003	NOTE 4

Notes:

1. Cold resistance measured per paragraph 5.8.2 of this specification.
2. Overload interrupt clearing times at +25°C. Clearing times at 250% overloads and -55°C may longer than those noted. PCB trace geometry may also affect clearing times below 400% overload levels.
3. 200% and 1000% overload interrupt clearing times also supplied with Group A data.
4. The maximum I²T (let-thru energy) can be calculated by squaring the given overload current and multiplying by the maximum clearing time specified.
5. The short circuit interrupt rating: 50 amperes for 1/4 to 3.0 amp ratings at rated voltage: 35 amperes for 4.0 to 7.0 amp ratings at rated voltage.

TABLE VII. FUSE ARC SUPPRESSANT AND MARKING COLOR IDENTIFICATION.

AEM PART NUMBER	ARC SUPPRESSANT GLASS COLOR	MARKING DESIGNATION BARS / DOTS	MARKING INK COLOR
SM1206-32-1/4	GREEN	2 BARS	WHITE
SM1206-32-3/8	GREEN	2 BARS	RED
SM1206-32-1/2	GREEN	2 BARS	BLUE
SM1206-32-3/4	GREEN	2 BARS	BLACK
SM1206-32-1.0	PINK	2 DOTS	WHITE
SM1206-32-1.5	PINK	2 DOTS	BLUE
SM1206-32-2.0	PINK	2 DOTS	GREEN
SM1206-32-3.0	PINK	2 DOTS	BROWN
SM1206-24-4.0	PINK	2 DOTS	YELLOW
SM1206-24-5.0	PINK	NONE	NONE
SM1206-24-6.0	PINK	2 DOTS	RED
SM1206-24-7.0	PINK	2 DOTS	ORANGE

AEM, Inc.		11525 SORRENTO VALLEY RD SAN DIEGO, CA 92121-1306.		TITLE SM1206 CURRENT LIMITING FUSE	
NUMBER	SM1206	REVISION	D	ECN	2136
				SHEET 10 of 18	

5.8 Methods of Examination and Test.

5.8.1 Visual and Mechanical Inspection. Fuses shall be visually and mechanically examined per AEM Process Instruction P71248.

5.8.2 Resistance. The resistance of the fuse shall be measured using a constant current DC source having an open circuit voltage not greater than the voltage rating of the fuse. The resistance of the fuse shall be measured using one of the following two methods:

Method I: The resistance shall be measured using a constant current DC source having an open circuit voltage not greater than the voltage rating of the fuse. The measurement current shall be from 0.1 to 10 milliamperes and provide a measurement accuracy of +/- 1%. A Keithley Model 580 Micro-Ohmmeter or equivalent is recommended for these measurements.

Method II: The fuses shall be electrically connected to a constant DC source supplying 10% of the rated current of the fuse and having an open circuit voltage not greater than the voltage rating of the fuse. The voltage drop of each fuse shall be measured and the resistance calculated from the measured voltage drop.

5.8.3 Thermal Shock. Fuses shall be tested in accordance with Method 107, Test Condition B, of MIL-STD-202. A total of five cycles shall be run without interruption.

5.8.4 Material Verification (Terminations). Fuse samples shall be subjected X-Ray Fluorescence (XRF) to determine that the tin/lead terminations are no more than 97% tin. This inspection shall be conducted after the completion of the tin/lead plating operation.

5.8.5 Material Verification of Substrate / Arc Suppressant (Qualification Only). Fuse raw materials shall be subjected to energy dispersive spectroscopy (EDS), also known as energy dispersive analysis of x-rays to determine the following:

- a) Existence of cadmium (none permitted).
- b) Existence of zinc (none permitted).

5.8.6 Current-Carrying Capacity. Fuse samples shall be apportioned and submitted to the following DC test currents at -55°C to -60°C, at +20°C to +35°C (room ambient temperature), and at +125°C to +130°C:

<u>Test Temperature</u>	<u>DC Test Current</u>
- 55°C	110% of Rated
+ 25°C	100% of Rated
+ 125°C	80% of Rated

The test current shall be maintained for 30 minutes after the temperature of each fuse has stabilized, but shall not be applied for less than 1.5 hours. It may be assumed that the temperature has stabilized when three consecutive temperature readings taken at 10 minute intervals show no rise in temperature. The temperature of the fuse body shall be measured by thermocouples (wire size 28 to 32 AWG). Group B current-carrying capacity testing shall be conducted at room temperature conditions only.

AEM, Inc.	11525 SORRENTO VALLEY RD SAN DIEGO, CA 92121-1306.	TITLE SM1206 CURRENT LIMITING FUSE
NUMBER SM1206	REVISION D	ECN 2136
		SHEET 11 of 18

5.8.7 Terminal Strength. Fuses shall be tested in accordance with Method 211 of MIL-STD-202. The following exceptions shall apply:

- a) Test Condition - Test Condition A (5-lb pull for fuses rated at 1.0 amp and higher; 4-lb pull for fuses rated at less than 1.0 amp) applying the force axially to each lead wire individually (solder .017 to .020 inch diameter wires to terminations prior to testing).
- b) Method of Holding - The fuse body shall be held by means other than rigid clamping to prevent stresses from being transferred to the fuse element.
- c) Measurements - DC resistance measurements shall be taken before and after exposure in accordance with 5.8.2.

5.8.8 Moisture Resistance (Group C / Qualification Only). Fuses shall be tested in accordance with Method 106 of MIL-STD-202. The following exceptions shall apply:

- a) Mounting - Normal mounting means by soldering onto a printed circuit board.
- b) No polarizing voltage shall be applied.
- c) Steps 7a and 7b are not applicable.
- d) Measurements - DC resistance measurements shall be taken before and after the exposure in accordance with 5.8.2.

5.8.9 Shock (Group C / Qualification Only). Fuses shall be tested in accordance with Method 213 of MIL-STD-202. The following details and exceptions shall apply:

- a) Mounting - Fuses shall be securely fastened to the table of the shock machine to prevent relative motion between the fuses and the table. Fuses may be solder mounted onto a test circuit board prior to fastening to shock machine table.
- b) Test Condition - F (1500Gs, 0.5 milliseconds, half-sine)
- c) Loading during Test - Rated DC current on half of the samples tested.
- d) Number of Shocks - Three shocks in each direction of three mutually perpendicular axes (18 shocks total).
- e) Measurements - DC resistance measurements shall be taken before and after the shock exposure in accordance with 5.8.2.

5.8.10 Vibration (Group C / Qualification Only). Fuses shall be tested in accordance with Method 204 of MIL-STD-202. The following details and exceptions shall apply:

- a) Mounting - Fuses shall be securely fastened to the table of the vibration machine to prevent relative motion between the fuses and the table. Fuses may be solder mounted onto a test circuit board prior to fastening to shock machine table.
- b) Test Level - Sinusoidal vibration from 5 to 3000 hertz, 0.4-inch double amplitude or 30G's peak, whichever is less.
- c) Sweep Rate - Approximately 1/2 octave per minute.
- d) Test Duration - 12 hours total (4 hours in each of three major axes).
- e) Loading during Testing - Rated DC current on half of the samples tested.
- f) Measurements - DC resistance measurements shall be taken before and after the vibration exposure in accordance with 5.8.2.

AEM, Inc.		11525 SORRENTO VALLEY RD SAN DIEGO, CA 92121-1306.		TITLE SM1206 CURRENT LIMITING FUSE	
NUMBER	SM1206	REVISION	D	ECN	2136
				SHEET 12 of 18	

5.8.11 Resistance to Soldering Heat. Fuses shall be tested in accordance with Method 210 of Mil-Std-202. The following details and exceptions shall apply:

- a) Solder temperature: 260°C ± 5°C.
- b) Immersion time: 10 ± 1 seconds.
- c) DC resistance shall be measured before and after the test in accordance with 5.8.2.

5.8.12 Low Temperature Operation (Group C / Qualification Only). Fuses shall be solder mounted onto a suitable test circuit board and placed in a low temperature chamber. The chamber temperature shall be lowered gradually to -55°C +0/-3°C within a period of 1 hour. After stabilizing at the low temperature for a period of 1 hour, rated DC current shall be applied to the fuses for a period of 4 +1/-0 hours while at the low temperature. The chamber shall then be gradually raised to room temperature within a 4-hour period and maintained at room temperature for a period of 8 hours minimum. After this time, the DC current shall be removed from the fuses and the fuses removed from the chamber. The DC resistance of the fuses shall be measured before and after the test in accordance with 5.8.2.

5.8.13 Life (2000 Hours, Group C / Qualification Only). Fuses shall be solder mounted onto a suitable test circuit board and placed in a chamber at +125°C +3/-0°C ambient. The fuses shall be electrically connected to a DC source supplying 64 percent of the +25°C rated current. The current source shall supply an open circuit voltage equal to the voltage rating of the fuses. The fuses shall remain in the chamber at the specified current for 2000 ± 8 hours. The electrical circuit shall provide a suitable indicator, which shall be monitored daily during the length of the life test, to identify failure (blowing) of any fuse. The time of failure shall be recorded to the nearest ± 12 hours and the blown fuse replaced with a short circuit for the remainder of the test. The DC resistance of the fuses shall be measured before and after the test in accordance with 5.8.2.

5.8.14 Overload Current. Fuses shall be subjected to the applicable percent of DC current (250%, 400% or 600%) as specified in Table VI. For Group B and Group C inspections, the fuses shall be tested while at case temperatures of +25°C to +35°C. For qualification inspection (Subgroup II, Table V) and Group C inspection (Subgroup II, Table IV) the fuses shall be divided equally and tested at +25°C to 35°C, and at +125°C to +130°C. The low impedance source shall be adjusted to supply an open circuit voltage equal to the rating of the fuse. The time to "blow" (the interval measured from the application of the current to the time the current drops below the rating of the fuse) shall be measured for each fuse. Each fuse shall remain in the test circuit for 1 minute after the fuse opens to check for restrike conditions. The maximum clearing I²T shall be determined using an oscillogram showing the current trace. The determination shall be made by application of Simpson's rule. A recommended test circuit is shown in Figure 2.

5.8.15 Resistance after Firing. The open resistance of the "blown" fuse shall be measured by applying rated DC voltage across the terminals of the fuse. The resistance value shall be taken after a one-minute application of the test voltage.

5.8.16 Thermal Vacuum (Qualification Only). Fuses shall be solder mounted onto a suitable test circuit board. The fuses shall then be placed in a vacuum chamber and the chamber evacuated to a pressure of 5 X 10⁻⁵ torr maximum. The temperature of the fuse mount shall be controlled such that the temperature of the fuses, measured with a thermocouple mounted on the fuse body, is maintained at +125°C +/- 3°C for a period of 48 +4, -0 hours, while 90% of the +25°C rated current is flowing through each fuse. At the end of the 48 hour exposure and while the fuses are at the test temperature and pressure, half of the samples shall be given an overload current at 400 percent of their rated current using the procedure specified in 5.8.14. The fuses shall then be removed from the chamber and the remaining fuses (not blown) measured for DC resistance in accordance with 5.8.2.

AEM, Inc.	11525 SORRENTO VALLEY RD SAN DIEGO, CA 92121-1306.	TITLE SM1206 CURRENT LIMITING FUSE
NUMBER SM1206	REVISION D	ECN 2136
		SHEET 13 of 18

5.8.17 Salt Spray (Group C / Qualification Only). Fuses shall be tested in accordance with Method 101 of MIL-STD-202. The following details shall apply:

- a) Five percent salt solution.
- b) Test Condition B.
- c) Following the drying period, the fuses shall be subjected to 100 percent of rated current for 1 hour.
- d) Following the test the fuses shall be examined for compliance with 4.8.14.

5.8.18 Outgassing. The fuses or fuse materials shall be tested as specified in ASTM E595.

5.8.19 Short Circuit Interrupt (Group C / Qualification Only). Fuses shall be placed in a DC test circuit capable of supplying a minimum of 35 or 50 amperes. The test circuit shall be made using appropriate generating equipment as a source of power and with the rate of current rise for the test circuit adjusted for at least 3.25×10^6 amperes per second. The open circuit voltage of the test circuit shall be adjusted to a value equal to the maximum rating of the fuse to be tested.

6. INSTALLATION

6.1 Mounting. Fuses may be mounted directly onto a printed circuit board.

AEM, Inc.	11525 SORRENTO VALLEY RD SAN DIEGO, CA 92121-1306.	TITLE SM1206 CURRENT LIMITING FUSE	
NUMBER SM1206	REVISION D	ECN 2136	SHEET 14 of 18

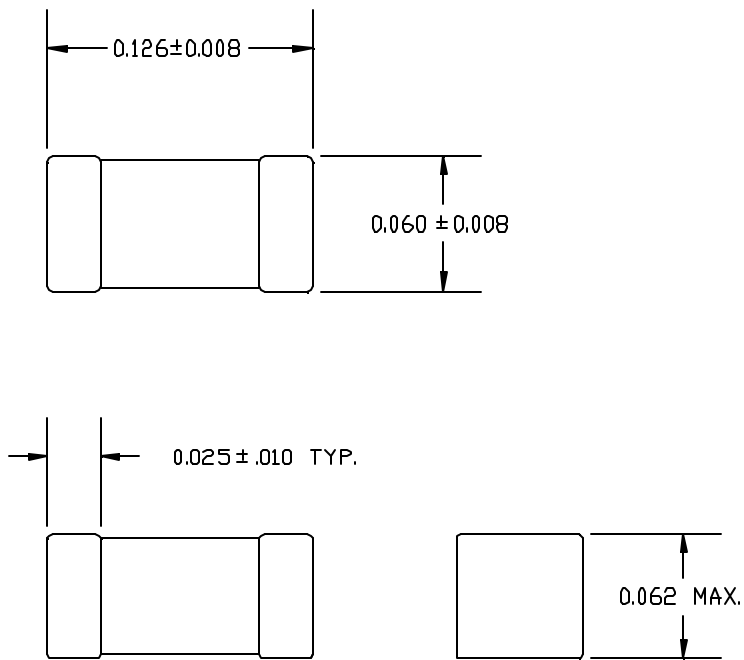

Notes:

1. Dimensions are in inches. Drawing is not to scale.
2. Thick film construction (Au element).

FIGURE 1. DIMENSIONS, CONSTRUCTION AND MARKING.

AEM, Inc.	11525 SORRENTO VALLEY RD SAN DIEGO, CA 92121-1306.	TITLE SM1206 CURRENT LIMITING FUSE	
NUMBER SM1206	REVISION D	ECN 2136	SHEET 15 of 18

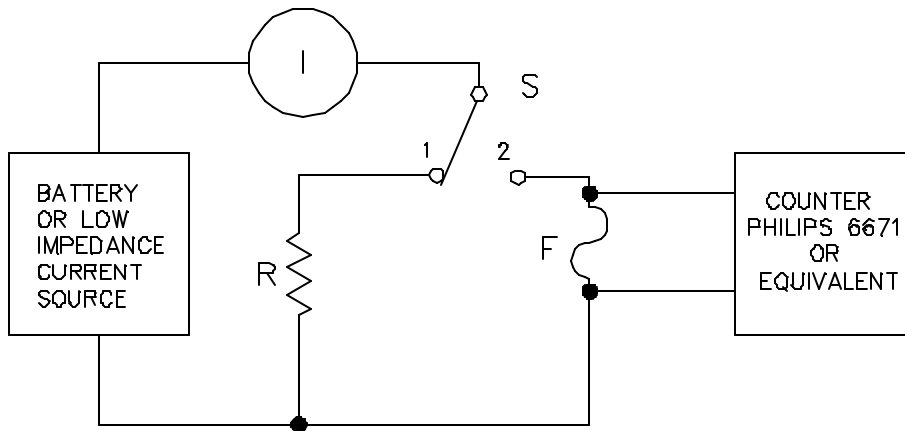

NOTES:

- R = Non-inductive resistor equal to the ohmic value of the fuse being tested.
- S = Non-bounce high current switch.
- I = Current adjusted to percent overload with switch in position 1.
- F = Current limiting fuse under test.

FIGURE 2. OVERLOAD CURRENT TEST CIRCUIT.

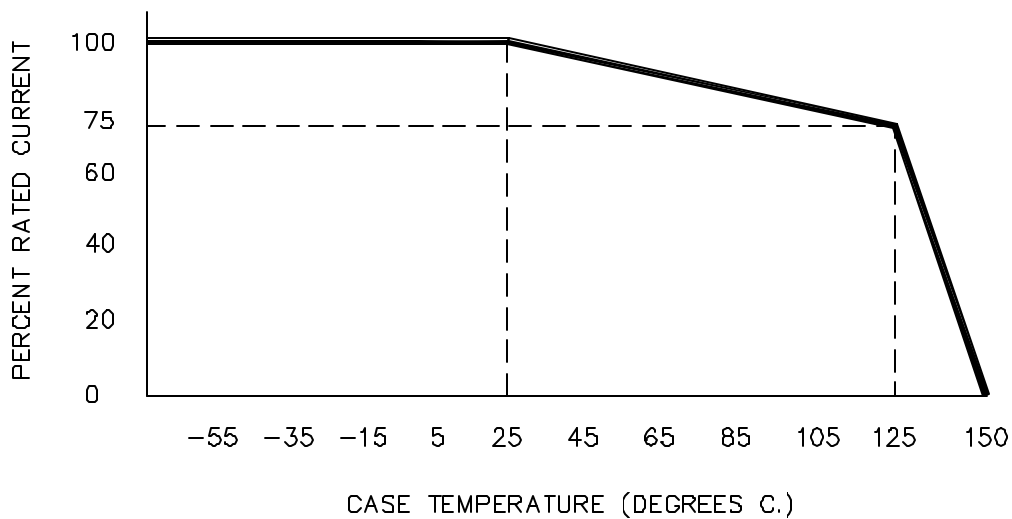

FIGURE 3. CURRENT DERATING LIMITS.

AEM, Inc.	11525 SORRENTO VALLEY RD SAN DIEGO, CA 92121-1306.	TITLE SM1206 CURRENT LIMITING FUSE	
NUMBER SM1206	REVISION D	ECN 2136	SHEET 16 of 18

DOCUMENTATION CHANGE NOTICE

<u>REV. LETTER</u>	<u>REV. DATE</u>	<u>PAGE</u>	<u>CHANGE ITEM</u>	<u>APPROVAL</u>
A	2/99	N/A	Issue New Drawing	JM 2-23-99
B	10/01	N/A	Entire document re-typed and all pages renumbered.	
		3	Added references to AEM P70435 and P71248 to paragraph 3.1.	
		5	Added paragraph 4.9 for traceability requirements.	
		5	Modified paragraph 5.4 to include Group A and B data.	
		7	Revised Group B Table III to include Resistance to Soldering Heat, Termination Strength, and Current-Carrying Capacity Testing.	
		8	Corrected Group C (Table IV) to include Overload Current and Resistance after Firing tests in Subgroup V.	
		9	Modified Qualification (Table V) to include note for sample size of Outgassing Test in Subgroup VI.	
		10	Revised Table VI to include 1/2, and 3/4 fuse options. Added electrical values in place of TBD values. Added notes 4 and 5. Revised resistance limits for 1.0 and 2.0 amp options.	
		11	Modified 5.8.1 to include reference to P71248.	
		11	Modified 5.8.4 to include requirement for termination material verification.	
		11	Modified 5.8.5 to include requirement for material verification of substrate and arc suppressant.	
		12	Modified 5.8.7 to include two test weights for fuses under 1.0 amp and greater than or equal to 1.0 amp.	
		13	Modified 5.8.8, 5.8.9 and 5.8.10 to indicate solder mounting of fuses prior to testing.	
C	5/02	8	Removed Overload Current Test from Subgroup V of Group C Inspection sequence.	JM 5/02
		9	Added Terminal Strength Testing Subgroup VII to Qualification sequence.	
D	9/03	3	Revised 4.2 to include marking color/ arc suppressant and Table VII reference.	

AEM, Inc.		11525 SORRENTO VALLEY RD SAN DIEGO, CA 92121-1306.		TITLE SM1206 CURRENT LIMITING FUSE	
NUMBER	SM1206	REVISION	D	ECN	2136
				SHEET 17 of 18	

DOCUMENTATION CHANGE NOTICE

<u>REV. LETTER</u>	<u>REV. DATE</u>	<u>PAGE</u>	<u>CHANGE ITEM</u>	<u>APPROVAL</u>
D	9/03	8	Revised Table IV to indicate 34 samples required.	
		10	Revised Table VI to include References to 1/4 and 3/8 amp fuse options.	
		10	Revised Table VI cold resistance values for 5.0 amp fuse to indicate .020 maximum.	
		10	Added Table VII to list arc suppressant and marking ink designations.	

AEM, Inc.	11525 SORRENTO VALLEY RD SAN DIEGO, CA 92121-1306.	TITLE SM1206 CURRENT LIMITING FUSE	
NUMBER SM1206	REVISION D	ECN 2136	SHEET 18 of 18